

# iMag Pro II™

*Credit Card Reader for iPhone 5, iPad mini, and iPad 4*

## Card Swiping on Your Apple 8-Pin Lightning Device

The ID TECH iMag Pro II is a magnetic stripe reader for all Apple Lightning connector devices: iPhones and iPads. Use your mobile device to read a variety of magnetic stripes including credit cards, signature debit cards, gift cards, loyalty cards, drivers licenses, and ID badges.

## Superior MagStripe Reading Performance

The iMag Pro II utilizes ID TECH's proven MagStripe reading technology, providing bi-directional card reading of up to three tracks of information. With a guaranteed operating life of at least 100,000 card swipes, the iMag Pro II offers exceptional card reading capabilities in a durable form factor.

## Incredible Convenience

ID TECH's iMag Pro II allows merchants to provide their customers with another acceptable method of payment, and with the capability to swipe credit cards merchants can save money by avoiding costly card-not-present fees. With the ID TECH iMag Pro II, merchants can accept credit card payments wherever they go.

## Features and Benefits:

- Supports TDES and AES encryption using DUKPT key management
- Reads up to three tracks of card data
- Superior MagStripe reader performance
- Bi-directional card reading
- Low battery consumption
- No external power supply required
- Small form factor for comfort and mobility
- Durable design that connects to any Apple 8-Pin mobile device
- Optional clip for the iPad 4 that provides additional support
- Micro-USB port for pass-through charging (charging cable not included)

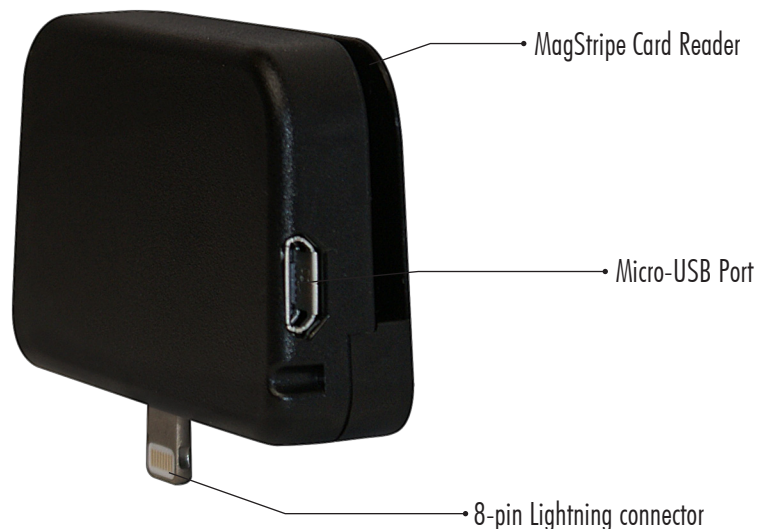

**IDTECH®**  
Value through Innovation

# iMag Pro II <sup>TM</sup>

## Specifications IDMR-AL30133

### Electrical

Power Consumption: 5 mA during swipe, 20 mA when idle  
Interfaces: Lightning connector

### Environmental

Operating Temperature: 32°F to 131°F (0°C to 55°C) non-condensing  
Storage Temperature: -22°F to 158°F (-30°C to 70°C) non-condensing  
Humidity: Maximum 95% non-condensing, dry storage

### Reliability

Operating Life: 100,000 cycles minimum  
Warranty: One year, parts and labor

### Mechanical

Media Thickness: 0.015 inches (0.381mm) to 0.035 inches (1.12mm)  
Media Formats: ISO 7811, AAMVA  
Swipe Speed: 3 to 60 inches per second, bi-directional  
Dimensions (L)x(W)x(H): 2.32 inches (59mm) x 0.52 inches (13mm) x 1.28 inches (32.6mm)  
Weight: 0.664 oz.

### Hardware Compatibility

- iPhone 5
- iPhone 5s
- iPhone 5c
- iPad mini
- iPad 4
- iPod touch

Footprint:

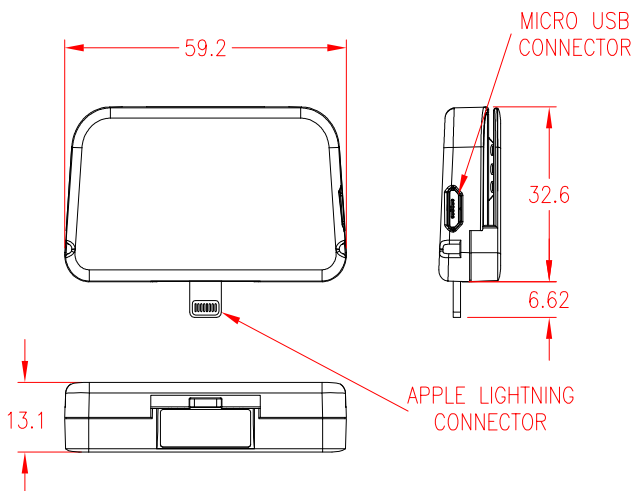

### United States Sales Office

#### Corporate Headquarters

10721 Walker Street  
Cypress, CA 90630  
Phone: (714) 761-6368  
Toll Free: (800) 984-1010  
Fax: (714) 761-8880  
sales@idtechproducts.com

### International Sales Offices

#### Asia

+866-3-496-6988 (Taiwan)  
asia@idtechproducts.com.tw

#### Canada

+450-465-5261  
robertop@idtechproducts.com

#### South America

+55-11-3079-2255  
internationalsales@idtechproducts.com

#### Europe

Germany & United Kingdom  
emea@idtechproducts.com

### ISO 9001 Certified

# IDTECH<sup>®</sup>

Value through Innovation

# VIVO<sup>®</sup>pay

www.idtechproducts.com

USB <sup>B</sup> CE FC

# Legacy Technology Services

**We Rent & Sell All Types Of Barcode Equipment**

Call now to talk to an expert

**866-271-9891**

[www.LegacyGlobal.com](http://www.LegacyGlobal.com)

Some brands we carry



MOTOROLA

**Intermec**

**DATALOGIC™**

**Honeywell**

**EQUINOX**  
PAYMENTS



## About us

- Legacy Technology Services is a leading nationwide provider of mobile computing, barcode, printers and point of sale equipment and services.
- For over a decade, thousands of clients across North America have trusted us to provide equipment from leading manufacturers backed by the services to support them.

## Latest Hardware from top manufacturers

- Legacy handles virtually every major manufacturer of mobile computing, barcoding and point of sale equipment.

## Expert Repair and Maintenance services

- Legacy is one of the best repair facilities in North America

## Discontinued product sourcing

- They don't make it anymore? Our inventory also includes manufacturer close-outs and discontinued equipment to support our clients legacy infrastructure.

## Trade-in and Disposal services

- That old equipment laying around your facility may still have some value. Legacy routinely purchases equipment from our clients around the globe.
  - Data destruction
  - Hardware disposal
  - Auditing services

## Dedicated client account team

- Dedicated, highly trained account managers are here to answer all your questions and provide top notch service.

## Equipment rental services

- Sometimes renting is a better solution, Legacy's huge rental inventory provides the equipment you need for temporary needs and projects.



[Legacy, Inc.](http://Legacy, Inc.)

160 West Road,  
Ellington, CT 06029

Toll Free: 866-271-9891

Fax: 888-522-4684